

OP-FL39-400CCT REFLECTOR 400W



- Reflector LED de alta potencia, con diseño compacto y elegante, ideal para la iluminación de fachadas, estacionamientos, plazoletas y exteriores en general.
- Ahorro energético de hasta un 90% gracias a su alta eficiencia, optimizando significativamente el consumo eléctrico.
- Lente de aumento, su función es concentrar la luz para una iluminación más suave y uniforme.
- Encendido instantáneo, sin tiempos de espera.
- No genera calor y no emite CO2.
- Soporte regulable giratorio, que permite direccionar la luz en diferentes ángulos,
- Cumple con la normativa **CE**, garantizando seguridad y calidad en su uso.



CARACTERÍSTICAS TÉCNICAS

Datos generales

Código:	OP-FL39-400CCT
Marca:	OPALUX
Tipo:	Reflector LED
Vida Útil:	50 000 horas
Garantía:	2 años

Características eléctricas

Potencia:	400 W
Alimentación:	86 – 265 V AC
Clase energética:	A+
Cantidad de LED:	576 piezas
Factor de potencia:	0.9

Características lumínicas

Flujo luminoso:	56 000 lm
Eficacia luminosa:	140 lm/W
Temperatura de color:	Cálido 3000 K Neutro 4000 K Frío 6500 K
Ángulo de proyección:	120°

Características de operación

Uso recomendado:	Interiores y exteriores
Grado de protección:	IP66
Resistencia de impacto:	IK08
Temperatura de trabajo:	-20 °C a +45 °C

Características físicas

Material de la carcasa:	Aluminio
Material del difusor:	PC de alto impacto transparente
Cantidad por caja máster:	5 unidades

CLASE DE ENERGÍA



DIMENSIONES

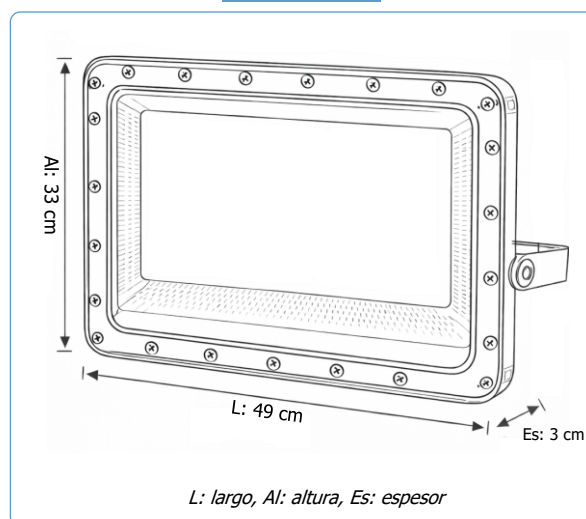

Lightsource Test Report

Product Information

Product Type: FL319-400W CCT

Product Number: 1

CIE Colorimetric Parameters

Chromaticity coordinates: $x=0.4323$ $y=0.3877$ $u(u')=0.2548$ $v=0.3427$ $v'=0.5140$

CCT: $T_c=2941K$ ($duv=-0.00605$)

Color Ratio: $R=0.238$ $G=0.736$ $B=0.026$

Peak Wavelength: 605nm

Half Bandwidth: 126.8nm

Dominant Wavelength: 585.5nm

Color Purity: 0.461

CRI: R_i : $R_a=83.6$

$R_1=83$

$R_2=93$

$R_3=95$

$R_4=81$

$R_5=84$

$R_6=91$

$R_7=81$

$R_8=61$

$R_9=15$

$R_{10}=82$

$R_{11}=80$

$R_{12}=74$

$R_{13}=86$

$R_{14}=98$

$R_{15}=77$

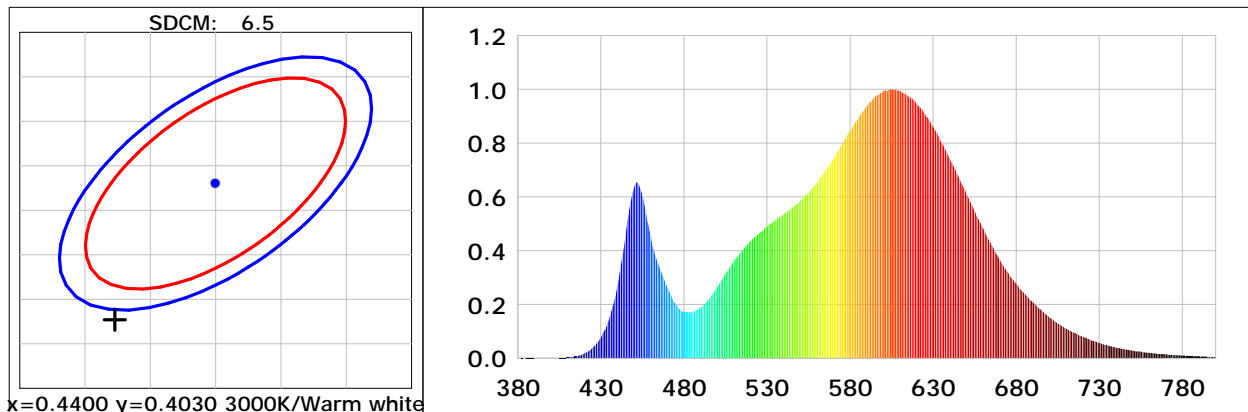

Photometric Parameters

Luminous Flux: 36817.6 lm

Efficiency: 93.28 lm/W

Radiant Power: 102.718 W

Electric Parameters

Voltage: 216.90V

Current: 1.8980A

Power: 394.70W

Power Factor: 0.9580

Frequency: 49.99Hz

Test Information

Scan Range: 380nm~800nm: 1nm Photometric Method: sphere-spectroradiometer

Stabilization Time: 0 Sec

Photometric Condition: Sphere diameter: 1.50m, 4T

Max of Signal: 47964 (3123)

CCD Integration Time: 13.86 ms

Condition: $T_x:25.2^{\circ}C$, $T_i:22.4^{\circ}C$, R.H.:60%

Test Lab:

Operator:

Test Device: Inventfine CMS-2S (Plus)

Test Time: 2026-01-08 16:58:34

Inspector:

Lightsource Test Report

Product Information

Product Type: FL319-400W CCT

Product Number: 4

CIE Colorimetric Parameters

Chromaticity coordinates: $x=0.3683$ $y=0.3591$ $u(u')=0.2242$ $v=0.3278$ $v'=0.4917$

CCT: $T_c=4228K$ ($duv=-0.00477$)

Color Ratio: $R=0.187$ $G=0.772$ $B=0.041$

Peak Wavelength: 452nm

Half Bandwidth: 22.6nm

Dominant Wavelength: 581.9nm

Color Purity: 0.183

CRI: R_i : $R_a=87.0$

$R_1=87$

$R_2=93$

$R_3=95$

$R_4=86$

$R_5=87$

$R_6=89$

$R_7=87$

$R_8=72$

$R_9=29$

$R_{10}=82$

$R_{11}=86$

$R_{12}=64$

$R_{13}=89$

$R_{14}=97$

$R_{15}=84$

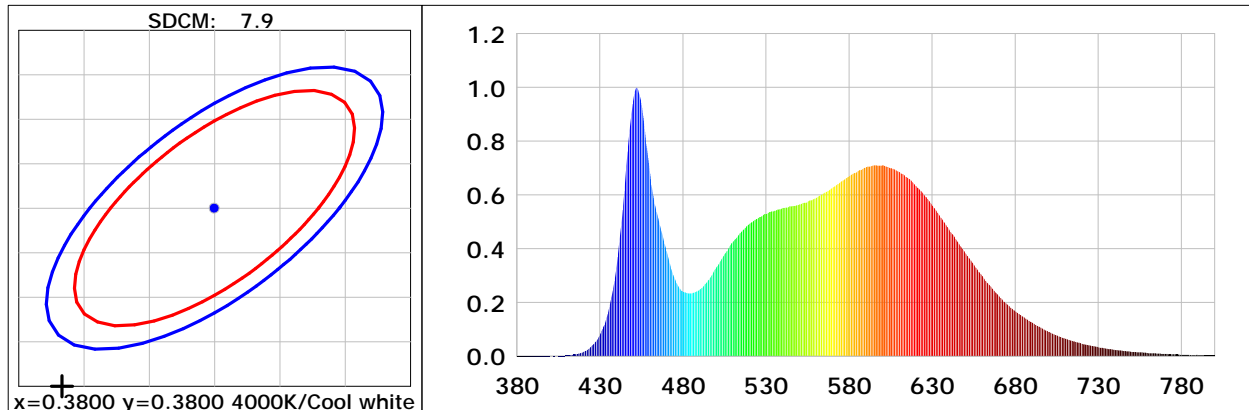

Photometric Parameters

Luminous Flux: 47484.2 lm

Efficiency: 126.76 lm/W

Radiant Power: 114.085 W

Electric Parameters

Voltage: 217.30V

Current: 1.7970A

Power: 374.60W

Power Factor: 0.9600

Frequency: 49.99Hz

Test Information

Scan Range: 380nm~800nm: 1nm Photometric Method: sphere-spectroradiometer

Stabilization Time: 0 Sec

Photometric Condition: Sphere diameter: 1.50m, 4T

Max of Signal: 50657 (3110)

CCD Integration Time: 8.57 ms

Condition: $T_x=25.2^\circ C$, $T_i=22.4^\circ C$, R.H.:60%

Test Lab:

Operator:

Test Device: Inventfine CMS-2S (Plus)

Test Time: 2026-01-08 16:59:41

Inspector:

Lightsource Test Report

Product Information

Product Type: FL319-400W CCT

Product Number: 6

CIE Colorimetric Parameters

Chromaticity coordinates: $x=0.3136$ $y=0.3342$ $u(u')=0.1965$ $v=0.3141$ $v'=0.4712$
 CCT: $T_c=6424K$ ($duv=0.00539$) Color Ratio: $R=0.134$ $G=0.810$ $B=0.056$
 Peak Wavelength: 452nm Half Bandwidth: 24.0nm
 Dominant Wavelength: 492.3nm Color Purity: 0.066
 CRI: R_i : $R_a=85.2$
 R1 =85 R2 =86 R3 =85 R4 =90 R5 =84 R6 =79 R7 =94 R8 =79
 R9 =24 R10=64 R11=89 R12=48 R13=85 R14=91 R15=82

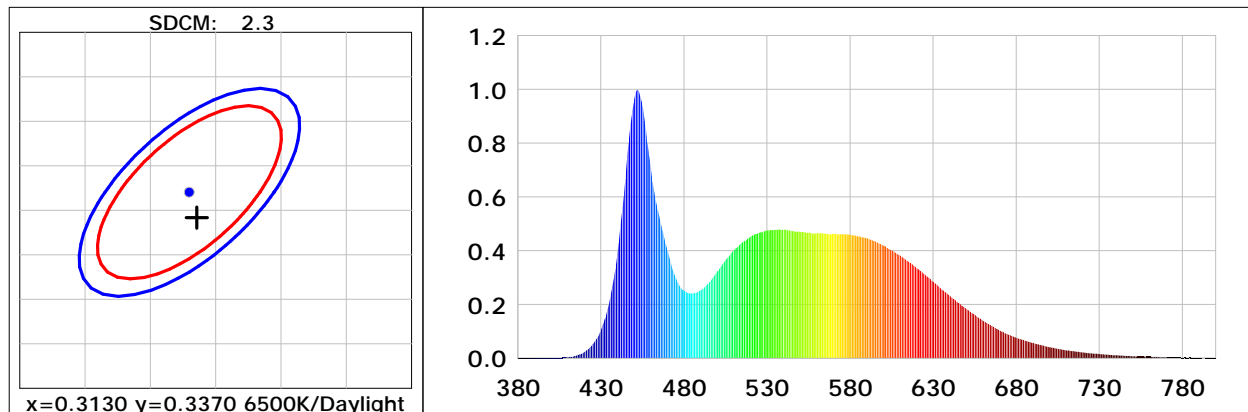

Photometric Parameters

Luminous Flux: 37551.7 lm

Efficiency: 95.14 lm/W

Radiant Power: 107.049 W

Electric Parameters

Voltage: 217.10V

Current: 1.8960A

Power: 394.70W

Power Factor: 0.9590

Frequency: 49.99Hz

Test Information

Scan Range: 380nm~800nm: 1nm Photometric Method: sphere-spectroradiometer
 Stabilization Time: 0 Sec Photometric Condition: Sphere diameter: 1.50m, 4T
 Max of Signal: 50670 (3102) CCD Integration Time: 6.95 ms

Condition: Tx:25.2°C, Ti:22.5°C, R.H.:60%
 Test Lab:
 Operator:

Test Device: Inventfine CMS-2S (Plus)
 Test Time: 2026-01-08 17:00:35
 Inspector: